

Description

828 Container/Pallet Loader
7 500 Kg (16,500 lbs)
929 Main Deck Loader
15 000 Kg (33,000 lbs) or 20 000 Kg (44,000 lbs)



II. Configurations, continued

TLC 828 and TLC 929 are self-propelled loaders with dual-platforms on scissor lifts. Cargo and lift systems are designed for loading and unloading as follows:

- TLC 828 – all models – handles cargo weighing up to 7 500 kg (16,700 lbs)
- TLC 929 handles cargo weighing up to 15 000 kg (33,000 lbs).
- TLC 929S handles cargo weighing up to 20 000 kg (44,000 lbs).

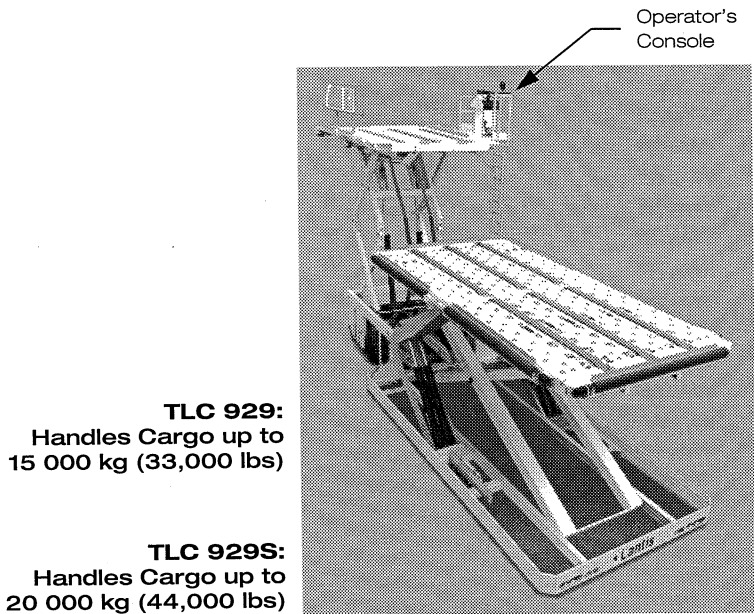
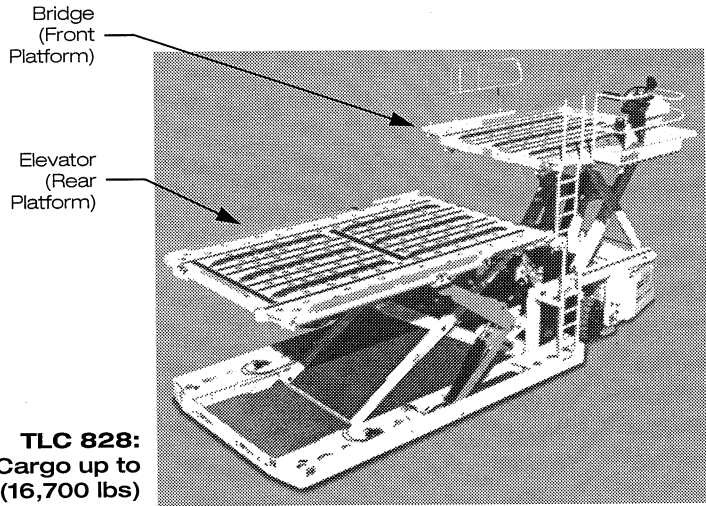

Figure 1: Dual-platform Scissor Lifts

II.A. Aircraft and Cargo Compatibility

TLC 828 and TLC 929 are designed to service aircraft as follows:

	Lower Lobe:	—————	Main Deck	—————
	747, 757, 767, 777		707, 727, 737	757, 767
	DC-10, MD-11, L-1011		BAE-146, A320	747, DC-10
	A300, A310, A320		DC-8, DC-9, MD-80	A300, A310
	A330, A340			MD-11, A330
				A340
828 STD & WID	—————			
828 UNI	—————		● ● ● ● ● ● ● ●	
828 SUP	—————		● ● ● ●	
929 & 929S	—————			

Solid line = Straight Transfer Dotted line = Bridge Shuttle

Figure 2: Aircraft Compatibility

TLC 828 and TLC 929 feature fold-down trays to accommodate door sizes as follows:

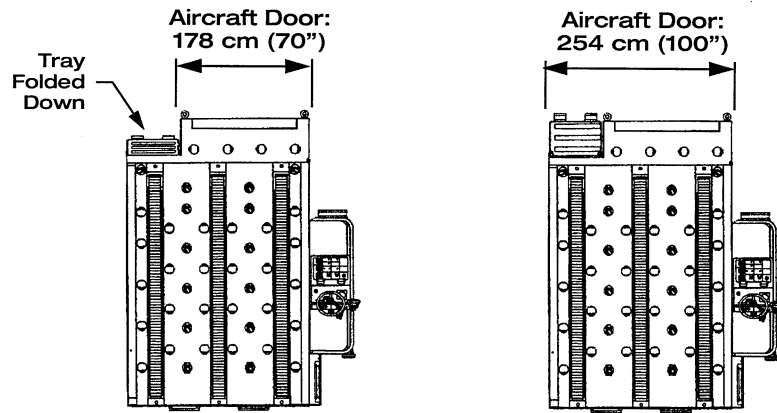

Figure 3: 828 STD

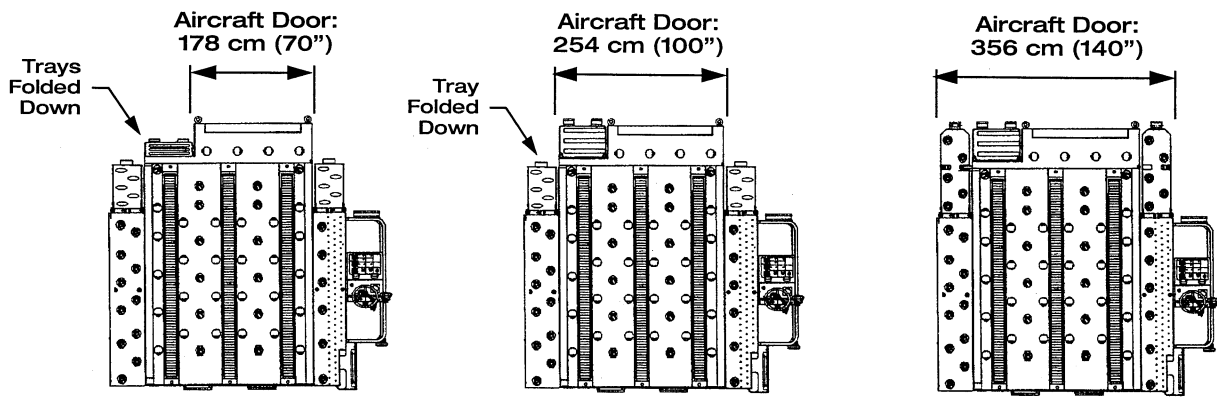

Figure 4: 828 WID, 828 UNI, 828 SUP, 929, & 929S

TLC 828 and TLC 929 are designed to handle cargo as follows:

- Containers: LD-1 through LD-11
- Pallets: 224 x 318 cm (88" x 125") and 244 x 318 cm (96" x 125")

In addition, 929 and 929S are designed to handle 610 cm (20 ft.) ULD's.

Description

828 Container/Pallet Loader
7 500 Kg (16,500 lbs)
929 Main Deck Loader
15 000 Kg (33,000 lbs) or 20 000 Kg (44,000 lbs)



II.B. TLC 828 and TLC 929 Models

TLC 828 and TLC 929 models are available as follows:

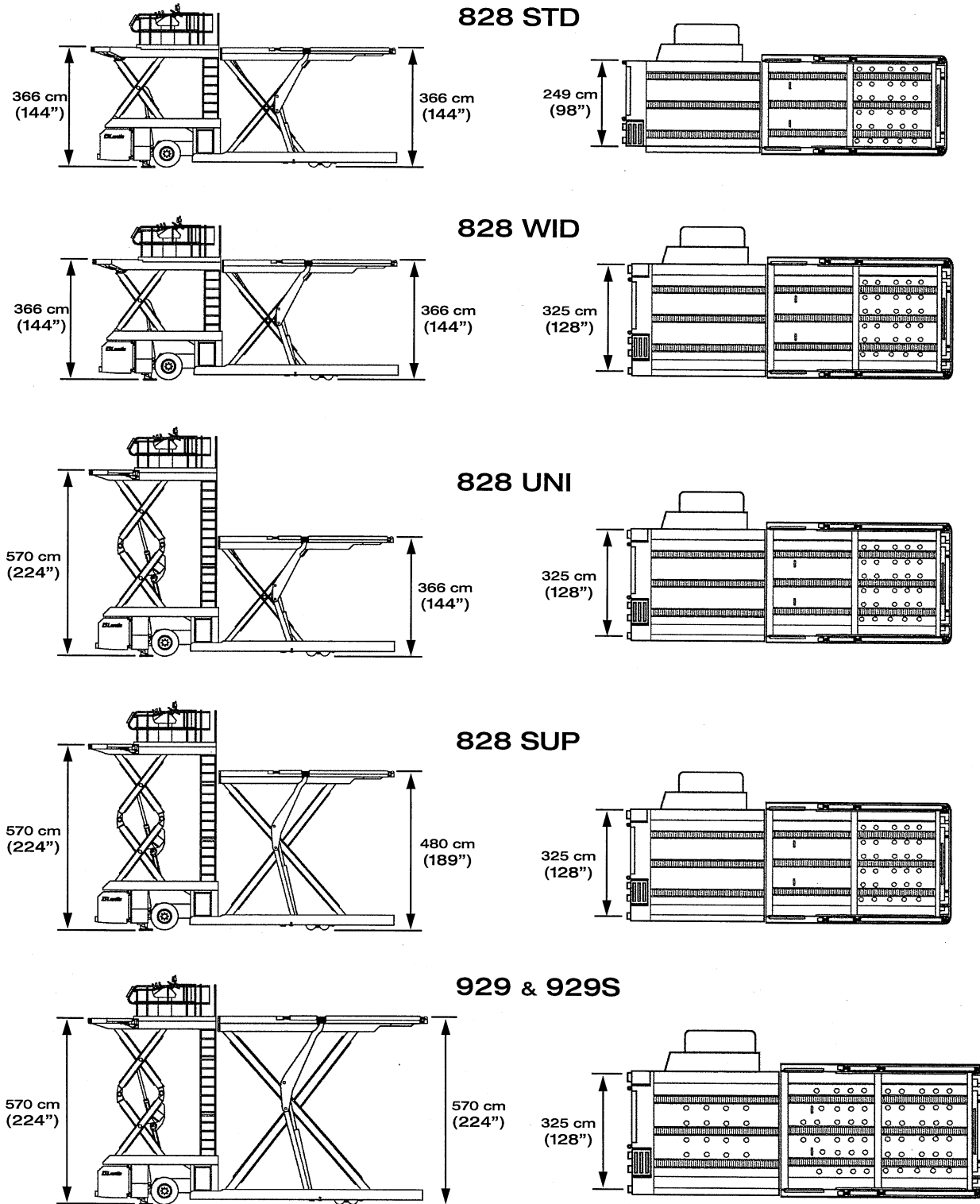

Figure 5: TLC 828 and TLC 929 Models

Specifications

828 Container/Pallet Loader
7 500 Kg (16,500 lbs)
929 Main Deck Loader
15 000 Kg (33,000 lbs) or 20 000 Kg (44,000 lbs)



III. Overall Specifications

Wheel Base

828 – all models	455 cm (179")
929 & 929S	566 cm (223")

Track Width

828 – all models	208 cm (82") — front 264 cm (104") — rear
929 & 929S	208 cm (82") — front 272 cm (107") — rear

Overall Height

828 STD & WID	295 cm (116") — lowered 485 cm (191") — raised
828 UNI & SUP	302 cm (119") — lowered 686 cm (270") — raised
929 & 929S	302 cm (119") — lowered 686 cm (270") — raised

Overall Size

828 STD	384W x 930L cm (151"W x 366"L)
828 WID, UNI, & SUP	411W x 930L cm (162"W x 366"L)
929 & 929S	417W x 1 120L cm (164"W x 441"L)

Shipping Dimensions

828 STD	297W x 930L x 198H cm (117"W x 366"L x 78"H)
828 WID, UNI, & SUP	366W x 930L x 198H cm (144"W x 366"L x 78"H)
929 & 929S	366W x 1 120L x 198H cm (144"W x 441"L x 78"H)

Gross Weight (approx.)

828 STD	15 500 kg (34,000 lbs)
828 WID	17 500 kg (38,500 lbs)
828 UNI & SUP	19 100 kg (42,000 lbs)
929	25 000 kg (55,000 lbs)
929S	26 360 kg (58,000 lbs)

Variable 2-Speed Front Wheel Drive

828 Low: Forward or Reverse	8 km/h (0-5 mph)
828 High: Forward	16 km/h (1-10 mph)
929 & 929S	10 km/h (0-6 mph)

Transfer Capacity

828 – all models	7 500 kg (16,500 lbs) — each platform
929	15 000 kg (33,000 lbs) — for 610 cm (20 ft) ULD's
929S	20 000 kg (44,000 lbs) — for 610 cm (20 ft) ULD's



III.A. Bridge Specifications

Bridge Height

828 STD & WID	180 cm (71") — lowered 366 cm (144") — raised
828 UNI & SUP	188 cm (74") — lowered 570 cm (224") — raised
929 & 929S	188 cm (74") — lowered 570 cm (224") — raised

Overall Bridge Length

828 / 929 – all models	396 cm (156")
------------------------	---------------

Overall Bridge Width

828 STD	378 cm (149")
828 WID, UNI, & SUP	409 cm (161")
929 & 929S	409 cm (161")

Width Capacity

828 STD	249 cm (98")
828 WID, UNI, & SUP	325 cm (128")
929 & 929S	325 cm (128")

Lift Capacity

828 / 929 – all models	7 500 kg (16,500 lbs.)
------------------------	------------------------

Lift System

828 STD & WID	Single scissors with dual lift cylinders
828 UNI & SUP	Dual scissors with dual lift cylinders
929 & 929S	Dual scissors with dual lift cylinders

Lift speed

7,6 m/mn (25 ft/min)

Cargo Transfer

Standard for all 828 & 929	Triple flat-top chains for straight transfer
Side Shift Option for 828	Side-to-side transfer with MDW's
929 & 929S	Side-to-side transfer with MDW's

Rear Cargo Stop

Normally up, mechanically lowered when elevator interfaces with bridge

Front Cargo Stop

828 STD & WID	Not required
828 UNI & SUP	Included, with low deck / high deck interlocking control
929 & 929S	Not required

Side Guides

828 STD	One or both can be removed and stowed 158 cm (62") or 249 cm (98") wide Adjustable $\pm 7,6$ cm (3") side-to-side, forward ends
828 WID, UNI, & SUP	158 cm (62"), 249 cm (98"), or 325 cm (128") wide Adjustable $\pm 7,6$ cm (3") side-to-side, forward ends
929 & 929S	158 cm (62"), 249 cm (98"), or 325 cm (128") wide Adjustable $\pm 7,6$ cm (3") side-to-side, forward ends

Bridge Tilt

828 – all models	Option: ± 4 cm (1.6")
929 & 929S	Included: ± 4 cm (1.6")



III.B. Elevator Specifications

Elevator Height

828 STD, WID, & UNI	46 to 56 cm (18" to 22") — lowered 366 cm (144") — raised
828 SUP	46 to 56 cm (18" to 22") — lowered 480 cm (189") — raised
929 & 929S	46 to 56 cm (18" to 22") — lowered 570 cm (224") — raised

Overall Elevator Length

828 – all models	528 cm (208") — overall
828 – all models	422 cm (166") — between stops
929 & 929S	711 cm (280") — overall

Overall Elevator Width

828 STD	295 cm (116")
828 WID, UNI, & SUP	361 cm (142")
929 & 929S	361 cm (142")

Width Capacity

828 STD	249 cm (98")
828 WID, UNI, & SUP	325 cm (128")
929 & 929S	325 cm (128")

Lift Capacity

828 – all models	7 500 kg (16,500 lbs.)
929	15 000 kg (33,000 lbs.)
929S	20 000 kg (44,000 lbs.)

Lift System

828 – all models	Scissors with grasshopper lift mechanism Single lift cylinder on each side, with integrated counterbalance valves
929 & 929S	Scissors with grasshopper lift mechanism Dual lift cylinders on each side, with integrated counterbalance valves

Lift Speed

828 – all models (not turbo)	15 m/mn (50 ft/min)
828 Turbo	17,4 m/mn (57 ft/min)
929 & 929S	14 m/mn (45 ft/min)